

An innovative method for improving system efficiency by overfeeding evaporators arranged in parallel in R744 (CO₂) refrigeration systems has been developed.

It is well known that superheat control of evaporators introduces a significant energy loss, as the maximum evaporation temperature is limited by the temperature approach between air inlet temperature and refrigerant temperature at evaporator outlet (Fig. 1). Moreover the overall heat transfer capability is worsened, in comparison with the same overfed evaporator, by the fact that part of the evaporator contains a single-phase vapour flow .

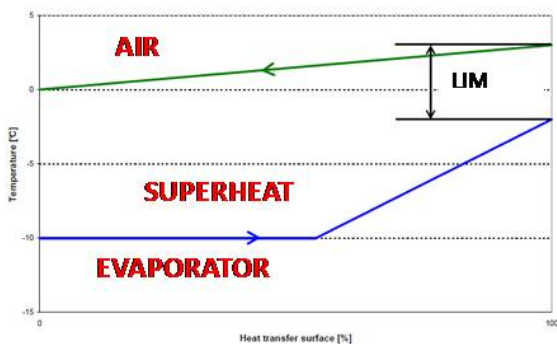

Fig 1. SH control

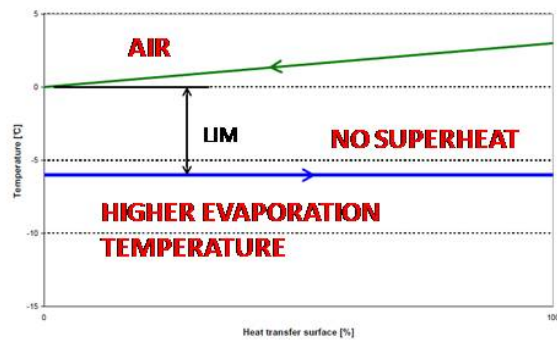
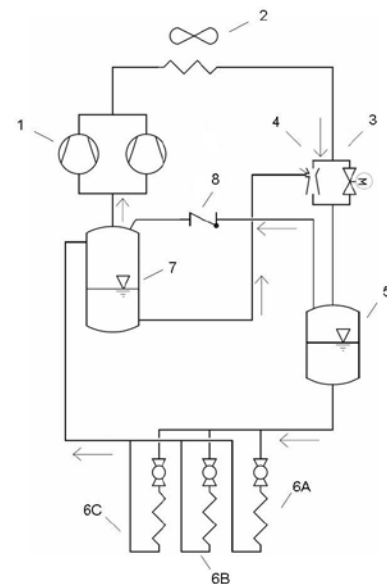

Fig 2. Overfed control

ASSESSMENT OF NEW DESIGN - EXPERIMENTAL ACTIVITY

A test rig was built to have a direct comparison between evaporator superheat control and overfed control obtained with liquid recirculation with “Enjector”. Refrigerant is compressed by (1) and heat is rejected in the condenser/gas cooler (2). High pressure fluid expands through the ejector (4) and energy recovered is used for pumping liquid - if any is present - from suction accumulator (7) into the intermediate pressure receiver - IPR - (5). A conventional high pressure valve (3) is used in parallel to Enjector for precise control of optimal high pressure. IPR is maintained by valve (8) at the set pressure, sufficient for fluid circulation through the 3 evaporators (6A, 6B and 6C). Expansion valves are controlled by a signal representing either the evaporator load –air ON– or the performance –air OFF– using a simple control algorithm. Suction pressure -SST- is automatically maintained by the compressors controller at the maximum/optimal value at any load condition.



The control of each evaporator can be switched to a conventional superheat control for comparison. Due to a special design for oil separation evaporators are fed with pure CO₂. Some tests, at different load conditions, were carried out.

An Infra-Red camera was used to qualitatively assess air inlet side of evaporator 6B, comparing overfed and superheat –SH– mode. Temperature of tube bends of the evaporator was measured with thermocouples.

TEST RESULTS FOR ONE CONDITION

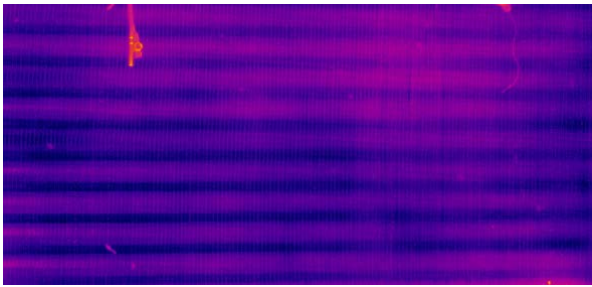

Fig 3. Evap. 6B - overfed

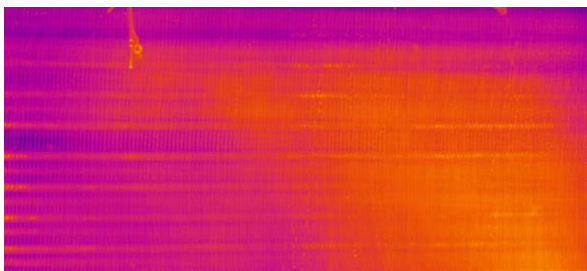

Fig 4. Evap. 6B - SH control

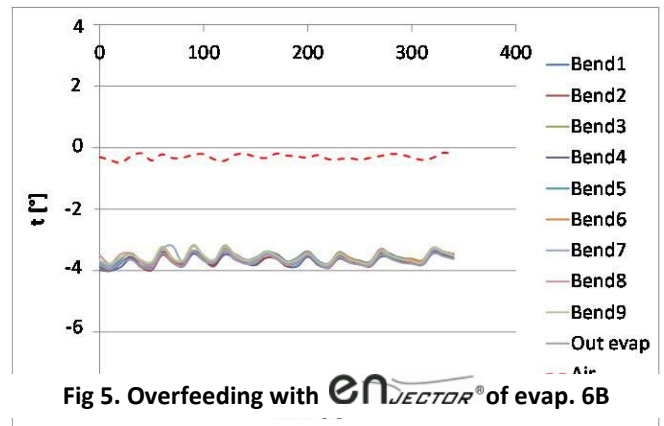
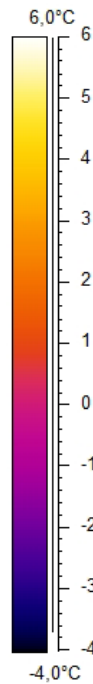

Fig 5. Overfeeding with enJECTOR® of evap. 6B

		Superheat control	Overfed
Condensing pressure	bar	59,7	59,0
Temperature at gas cooler out	°C	17,8	17,7
Cold room temperature – air OFF	°C	0	-0,2
Power input to compressors - measured	W	1980	1750
Cooling power - measured	W	6030	6050
COP	--	3,05	3,45

Measured increase of COP is 13%.

When compared to dry-expansion evaporator systems, the proposed solution offers energy saving and smoother operating conditions, still maintaining a simple plant lay-out, low refrigerant charge as well as a simple and trouble free design.

A further advantage of the system is the resilience towards liquid and oil slugs at compressors suction.

The advantage is even higher with typical evaporators used in commercial cabinets.

The system is available as an option on all the range of Enex units and it is fully compatible with controllers from leading manufacturers available on the market and with standard evaporators.

Patent Pending: PCT-WO 2012/168544 A1



Via Veneto, 12 31038 Paese (TV), Italia
 Tel. +39 0422 440429 /Fax +39 0422 961021
www.enex.it